

■ ADVANTAGE

- Double face.
- High impact resistant.
- Internal back-up battery provides 90 minutes operation during a power outage.
- Ultra bright, energy efficient, long life Red or green LEDs.
- Mounting: top mounted, side mounted.
- 5 years warranty.
- Applications: exit, hallways, doorways, etc.



■ DETAILS

Features

- Injection-molded, 5VA flame-retardant and high impact thermoplastic housing, this led emergency lights have high-impact resistant.
- High performance chrome-plated metallized reflector and plastic lens for optimal light distribution.
- Charge rate/power “ON” LED indicator light and push-to-test switch for mandated code compliance testing.
- Compact, low-profile design.

Installations

EZ-snap mounting canopy included for top or end mount.

- Suitable for wall mount.

Certifications

- Comply with the requirements of the Standard(s) for Luminaires and are identified with the cETL Listed Mark.

Accessories

- Screw and cap.
- Mounting fixing hardware.
- Canopy.

Warranty

- All products from DIMILIGHT are guaranteed with 5 years' warranty.
- See [Warranty policy from DIMILIGHT](#) for additional information.

■ DIMENSIONS

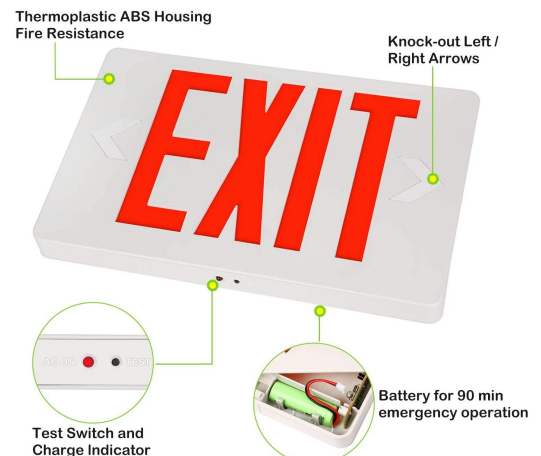

■ SPECIFICATION

	MODEL	WATT	INPUT VOLTAGE	EMERGENCY DURATION	CERTIFICATE
<input type="checkbox"/>	DM-EM114	5W	AC120V/277V	≥ 90 mins	cETLus

■ ACCESSORIES

Screw and Cap



Fixing Hardware

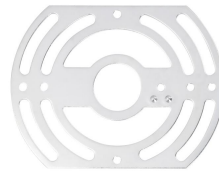

Canopy



■ PACKING INFO

MODEL	14PCS/CARTON	560PCS/PALLET		CONTAINER		
	DIMENSION(INCH)	N.W(LBS)	G.W(LBS)	20'GP(PCS)	40'GP(PCS)	40HQ(PCS)
DM-EM110	17.7" x12.7" x15.7"	35.3	18.8	7000	10000	12000

■ APPLICATION

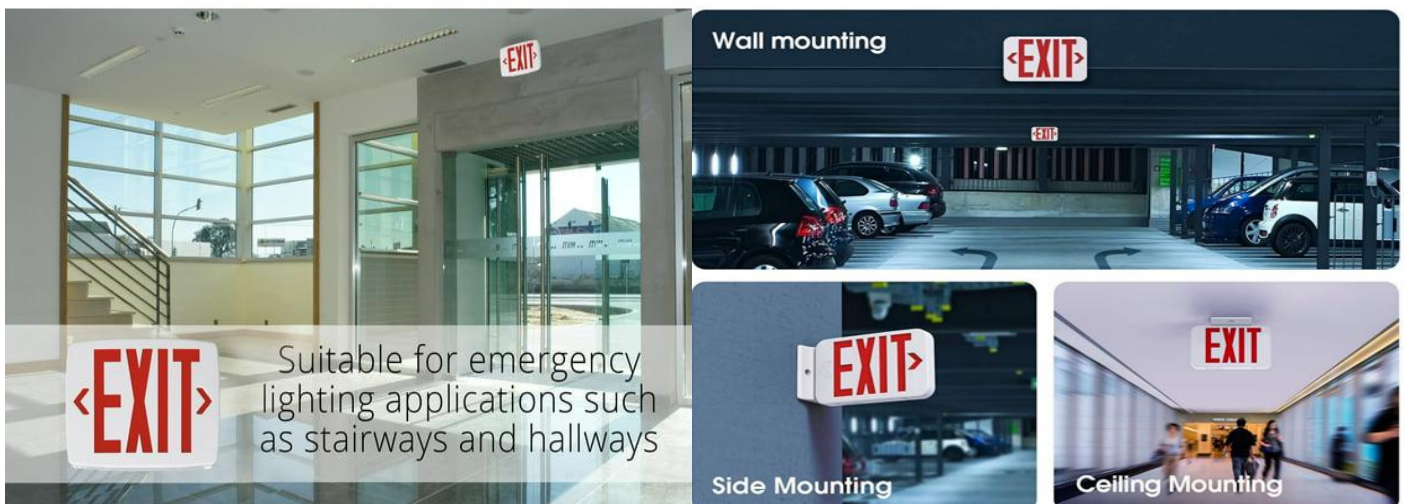

■ INSTALLATIONS

❖ Top mount

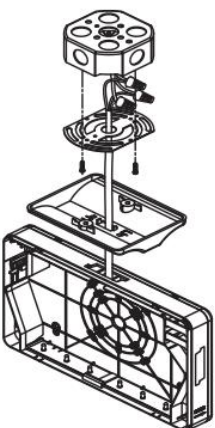
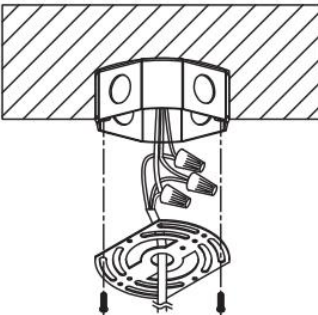
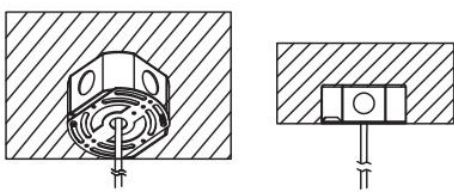
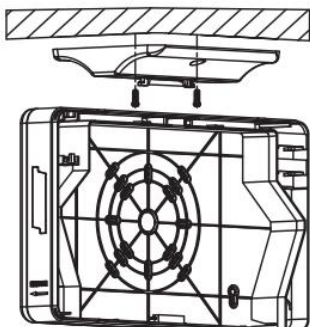
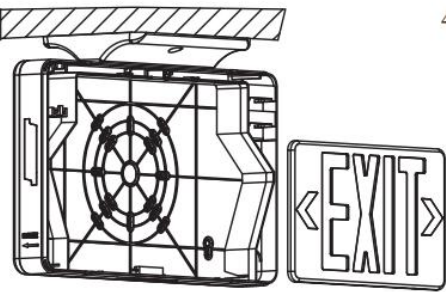
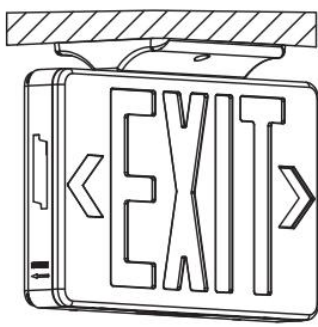
	 <p>1</p>	 <p>2</p> <p>1. Using the junction box screws to mount spider plate onto junction box.</p>
<p>1. Using a flat screwdriver, open the front cover, remove and discard the canopy kit. 2. Feed excess wires into the junction box. 3. The system can accept input voltages of 120VAC or 277VAC. Therefore, connect the black/red wire (line voltage) and the white wire (neutral) leads to the building utility. Connect the green ground.</p>		
 <p>3</p> <p>1. Install the canopy to junction box using the junction box screws.</p>	 <p>4</p> <p>1. Mount the unit securely to the canopy. 2. Snap the EXIT plate to the unit.</p>	 <p>5</p>

❖ Side mount

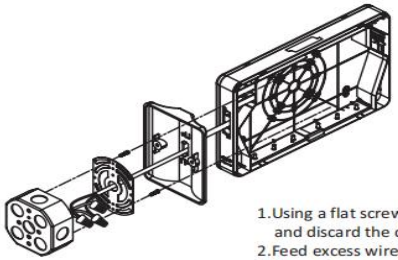
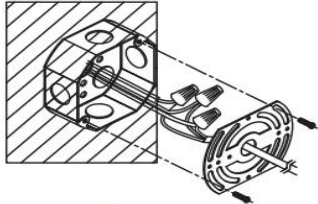
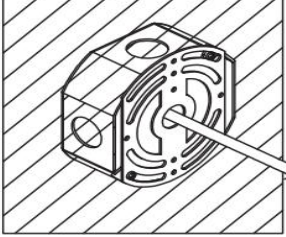
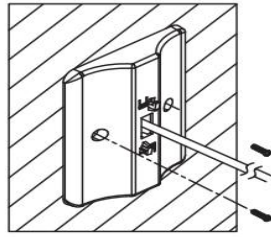
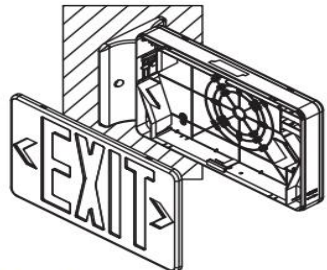
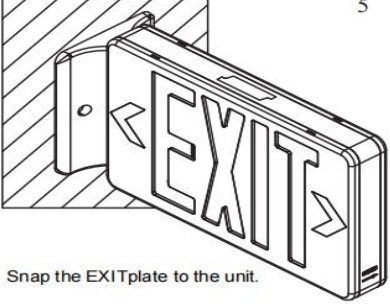
	 <p>1</p>	 <p>2</p> <p>1. Using the junction box screws to mount spider plate onto junction box .</p>
<p>1. Using a flat screwdriver, open the front cover, remove and discard the canopy kit. 2. Feed excess wires into the junction box. 3. The system can accept input voltages of 120 VAC or 277 VAC. Therefore, connect the black/red wire (line voltage) and the white wire (neutral) leads to the building utility. Connect the green ground.</p>		
 <p>3</p> <p>1. Insert the canopy onto the location where the mounting hole cover was removed</p>	 <p>4</p> <p>Mount the unit securely to the canopy</p>	 <p>5</p> <p>Snap the EXIT plate to the unit.</p>