

DOUBLE RING SURFACE MOUNT CEILING LIGHT

■ ADVANTAGE

- Wattage switchable :
16w (12in)
20w (14in)
24w (16in)
- CCT switchable: 2700K/3000K/3500K/4000K
5000K
- Triac dimmable
- Input voltage: 120V
- Lumen : 70Lm/W
- Application:residential housings,condominiums,business building,hoteland hospitality industry.



■ DETAILS

Features

- Emits evenly, without halo and shadow.
- Wattage and CCT switchable through dip-switches.
- Fit 3.5"/4" J-Box
- Easy to install

Applications

- Schools and universities
- Offices and municipal buildings
- Healthcare facilities and hospitals

Certifications

- DLC 5.1 premium.
- Comply with the requirements of the Standard(s) for luminaires (CAN/CSA-C22.2 No. 250.0) and are identified with the cETL Listed Mark.

Accessories

- Screws, Wire Nuts.

Warranty

- All products from DIMI LIGHT are guaranteed with 5 years' warranty.
- See [Warranty policy from DIMI LIGHT](#) for additional information.

■ DIMENSIONS

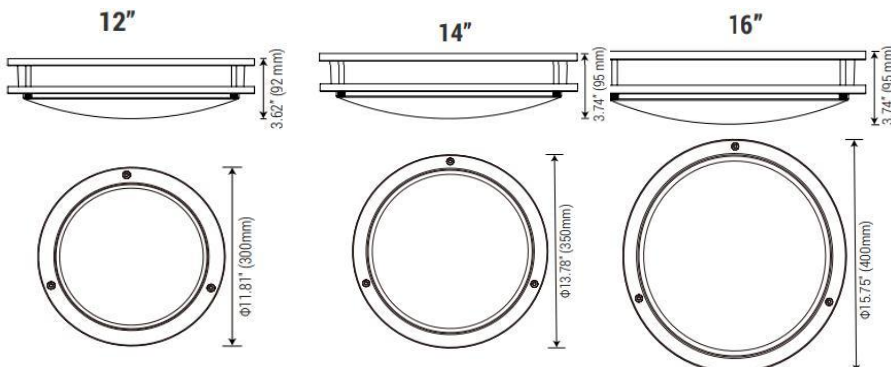

SIZE	L	W
12in	11.81"	3.62"
14in	13.78"	3.74"
16in	15.75"	3.74"

DOUBLE RING SURFACE MOUNT CEILING LIGHT

■ SPECIFICATION

	MODEL	SIZE	WATT	CCT	LM	CERTIFICATE
<input type="checkbox"/>	DM-CL12IN16W-5CCT	12in	16w	2700K/3000K/3500K/4000K/5000K switchable	70Lm/w	cETLus
<input type="checkbox"/>	DM-CL14IN20W-5CCT	14in	20w	2700K/3000K/3500K/4000K/5000K switchable	70Lm/w	cETLus
<input type="checkbox"/>	DM-CL16IN24W-5CCT	16in	24w	2700K/3000K/3500K/4000K/5000K switchable	70Lm/w	cETLus

■ ACCESSORIES

Screws



Wire Nuts

Screws

- Screws Perfect for accent lighting around pools, decks, or any other outdoor lighting scenerio
- Slim design,easy to install



Wire Nuts

- 330V maximum
- High quality material

■ PACKING INFO

SIZE	4PCS/CARTON			CONTAINER		
	DIMENSION(INCH)	N.W(LBS)	G.W(LBS)	20'GP(PCS)	40'GP(PCS)	40HQ(PCS)
12in	48.62"x13.00"x3.15"	29.20	35.20	504	972	1224
14in	24.80"x24.80"x3.15"	29.20	35.20	370	714	899
16in	48.62"x24.80"x3.15"	29.20	35.20	289	558	703

DOUBLE RING SURFACE MOUNT CEILING LIGHT

■ PACKING INFO

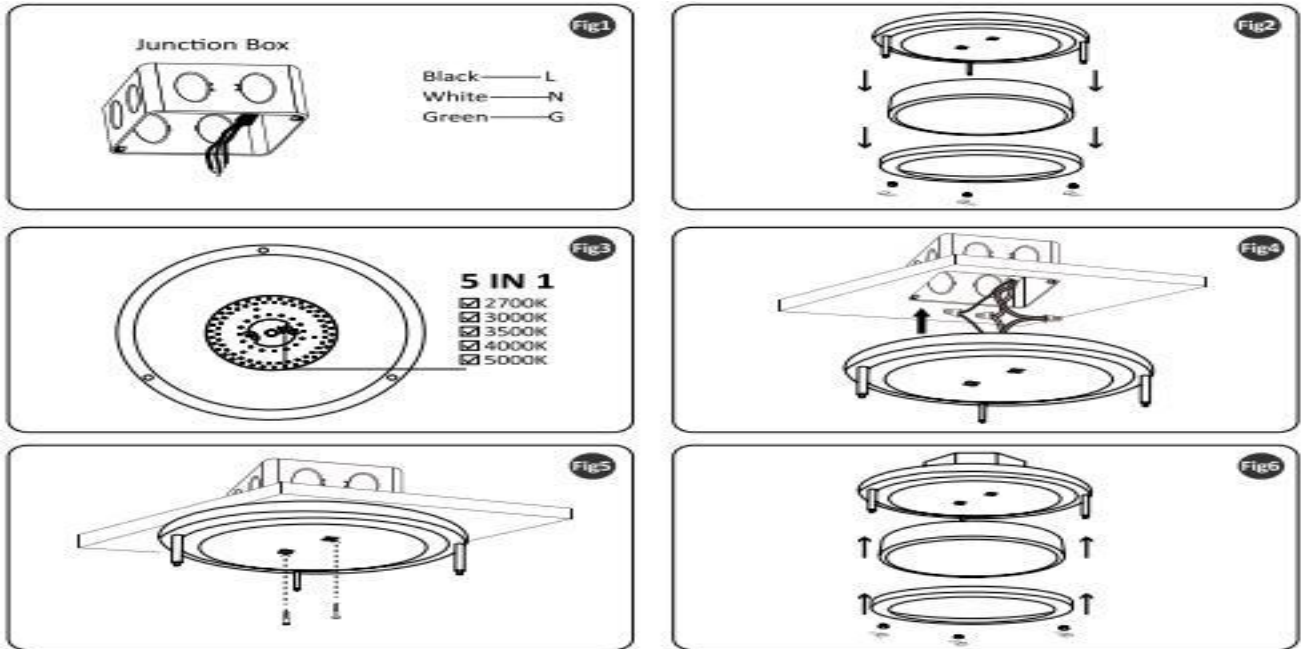

Step 1: Make sure power off and the Junction Box is mounted before installation.(This ceiling light is compatible with 2.75"and 3.5"Junction Box),see Fig.1

Step 2: Unscrew three cap nuts counter-clockwise, remove metal ring and the lens,see Fig2.

Step 3: Remove the two stickers at the ceiling light back that read as 2.75"and3.5" Junction Box installation hole to reveal the screw slots.Select lamp color desired with the CCT switch,see Fig3.

Step 4: Connect the supply wires to the wires of ceiling light by using 3 wire nuts.Attach white to white,black to black, gree to ground wire,see Fig4.

Step 5: Arrange the wires into the Junction Box.

Align appropriate slots in the ceiling light with the holes in the Junction Box.Use 2 screws to attach the ceiling light,flush with the ceiling ,see Fig5.

Step 6: Placing the metal ring and the lens back,screw three cap nuts firmly in clockwise direction,see Fig6.